

GCS InGaAs Quadrant Position Sensing PD

P/N: Do206_QD_1.5mm_P2

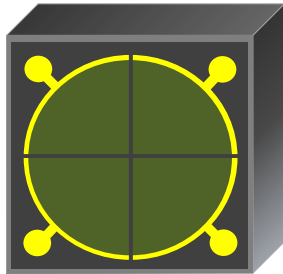

Known Good Die



Introduction

This product is a front-side illuminated InGaAs quadrant PIN photodiode that features a large 1.5mm detection window with four separated active areas. This product has a planar structure with each of four separate anodes on front side and a common cathode on backside. The product has high response uniformity and low cross-talk between channels, and is primarily designed for optical positioning application in the wavelength region from 980nm to 1620nm.

Key Features

- 1.5mm quadrant active window
- Planar structure on n+ InP substrate with 4 top anode contacts
- High responsivity and uniformity
- Low noise and cross-talk between channels
- Deliverable in GCS Known Good Die™ with 100% testing and inspection
- RoHS compliant
- Customized chip dimension available

Applications

- Position sensors
- Beam alignment
- Beam profiling

SPECIFICATIONS (T=25C°)

	Conditions	Min.	Typical	Max.	Unit	Notes
Responsivity ₁	1310nm	0.8	0.9	-	A/W	
Responsivity ₂	1550nm	0.9	0.95	-	A/W	
Channel gap		-	45	-	µm	
Capacitance	-5 V	-	25	35	pF	Per channel
Dark current	-5V	-	0.2	2	nA	Per channel
Bandwidth		-	0.1	-	GHz	Per channel

ABSOLUTE MAXIMUM RATING

Parameter	Rating
Reverse Voltage	-10V
Reverse Current	-1mA
Forward Current	10mA
Optical Power Input	10mW
Operating Temperature	-40C to 85C
Storage Temperature	-55C to 125C
Soldering Temperature	320C / 5 sec

Global Communication Semiconductors, LLC

23155 Kashiwa Court, Torrance, CA 90505

Tel: (310) 530-7274 Fax: (310) 517-8200 e-mail: info@gcsincorp.com

www.gcsincorp.com

COPYRIGHT GLOBAL COMMUNICATION SEMICONDUCTORS LLC. ALL RIGHTS RESERVED.

DIMENSIONS

	Conditions	Min.	Typical	Max.	Unit	Notes
Detection Window			1500		μm	Quadrant
Bonding pad diameter			275		μm	for anode
Metal height of bond pads			1.6	-	μm	Au metal
Die height		190	200	210	μm	
Die width		1775	1785	1795	μm	
Die length		1775	1785	1795	μm	

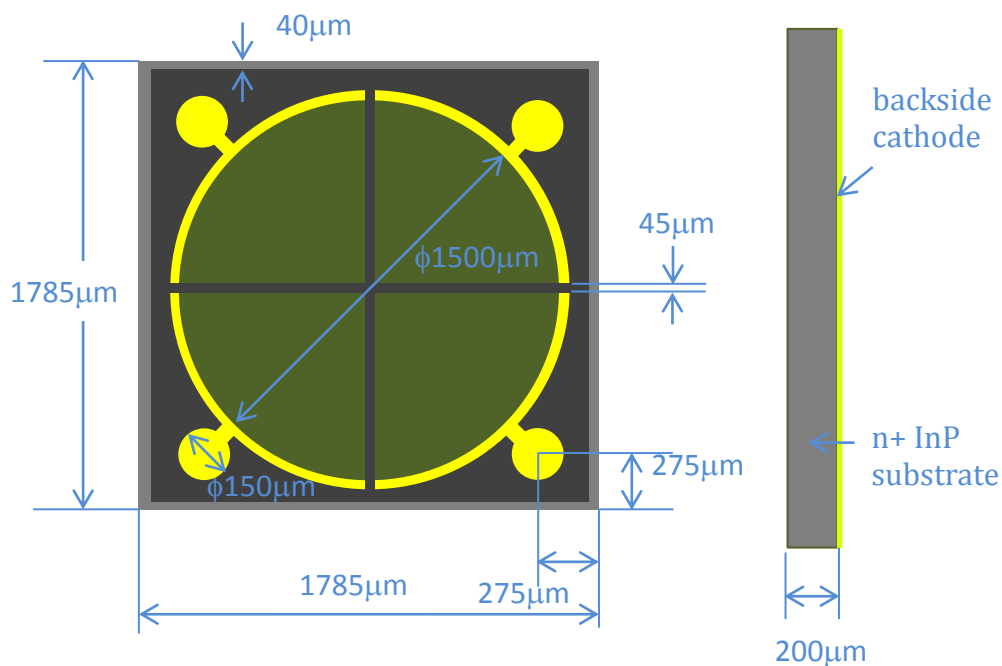

P/N: Do206_QD_1.5mm_P2

Attention: InP brittle material and electrostatic sensitive device, observe precaution for handling.

About GCS:

GCS has a long history manufacturing and shipping both GaAs and InGaAs based photo diodes since 2000. Our state of art manufacturing facility is located in Torrance, California, and has about 10,000 square feet of fab space with a capability of about 1200 4-inch wafers per month and expandable to 2000 wafers per month. GCS as a world-class semiconductor device manufacturer has been delivering a total of over 30 million photo diodes with various data rates and applications used for optical communications, which have been deployed in field by top tier optical transceiver companies worldwide. ■

Global Communication Semiconductors, LLC

23155 Kashiwa Court, Torrance, CA 90505

Tel: (310) 530-7274 Fax: (310) 517-8200 e-mail: info@gcsincorp.com

www.gcsincorp.com